

# SHURFLO PUMPS

2010

## 8000 SERIES DIAPHRAGM PUMPS - AUTOMATIC DEMAND PUMPS 12VDC



### Features:

- Self priming up to 8 vertical feet (2.4m)
- Chemical resistant materials
- Designed for heavy duty spraying and fluid transfer applications
- Can run dry without damage
- Built in check valve

The 8000 Series diaphragm pump is SHURflo's most widely used agriculture pump. With its conical shaped Viton® valves and automatic demand switch, the 8000 Series pump is the pump of choice for sprayers used on the farm or around the yard. These 12 VDC pumps deliver up to 1.8 GPM (6.8 l/min) providing maximum performance in a wide range of applications.

Model	Description	
<a href="#"><u>8000-543-136</u></a>	<b>Standard Demand Pump</b> 1.8 GPM open flow, Viton® valves, Santoprene® diaphragm, 60 PSI Demand Switch, 1/2" MSPT ports, Poly Housing	<b>\$ 98.00</b>
<a href="#"><u>8000-543-236</u></a>	<b>Standard Demand Pump</b> 1.8 GPM open flow, Viton® valves, Santoprene® diaphragm, 60 PSI Demand Switch, 3/8" NPT-Female ports, Poly Housing	<b>\$ 83.00</b>
<a href="#"><u>8000-543-238</u></a>	<b>High Pressure Demand Pump</b> 1.8 GPM open flow, Viton® valves, Santoprene® diaphragm, 100 PSI Demand Switch, 3/8" NPT-Female ports, Poly Housing	<b>\$86.00</b>
<a href="#"><u>8000-543-936</u></a>	<b>Standard Pump w/Wire Harness</b> 1.8 GPM open flow, Viton® valves, Santoprene® diaphragm, Prewired with two wire molded connectors, 60 PSI Demand Switch, 3/8" NPT-Female ports, Poly Housing	<b>\$89.00</b>

## 8000 SERIES DIAPHRAGM PUMPS - AUTOMATIC DEMAND PUMPS 115 VAC



### Features:

- Self priming up to 8 vertical feet (2.4m)
- Chemical resistant materials
- Can run dry without damage
- Built-in check valve
- UL/CUL recognized components

SHURflo 8000 and 8005 Series demand pumps provide the same reliability as the 12 VDC version, with flow rates up to 1.6 GPM (6.1 l/min). They are ideal in industrial applications that require high pressure, with low amp draw. They can be mounted in any position, are compact, and are design for easy maintenance.

Model	Description	
<a href="#"><u>8000-533-236</u></a>	<b>Standard Demand Pump</b> 1.4 GPM open flow, Viton® valves Santoprene® diaphragm, 60 PSI Demand Switch, 3/8" NPT-Female ports, Poly Housing	<b>\$115.00</b>
<a href="#"><u>8005-733-155</u></a>	<b>Standard Demand Pump w/Internal Bypass</b> 1.4 GPM open flow, EPDM valves, Santoprene® diaphragm, 60 PSI Demand Switch, w/45 PSI Internal Bypass, 1/2" MPT ports, Poly Housing	<b>\$ 96.00</b>
<a href="#"><u>8000-033-236</u></a>	<b>All Viton® Demand Pump</b> 1.0 GPM open flow, Viton® valves, 60 PSI Demand Switch, 3/8" NPT-Female ports, Poly Housing	<b>\$133.00</b>
<a href="#"><u>8000-713-238</u></a>	<b>High Pressure Demand Pump</b> 1.6 GPM open flow, EPDM valves, Santoprene® diaphragm, 100 PSI Demand Switch, 3/8" NPT-Female ports, Nylon Housing	<b>\$115.00</b>

## 8000 SERIES DIAPHRAGM PUMPS - B-YPASS PUMPS 12 VDC



### Features:

- Self priming up to 8 vertical feet (2.4m)
- Chemical resistant materials
- Internal bypass
- Can run dry without damage

Smooth internal bypass pumps are the answer to applications where an automatic demand switch is not required. Pumps with bypass will continue to run at high pressure. Ideal for intermittent duty applications. Perfect for transfer applications where smooth consistent flow is needed. They can be mounted in any position, and are designed for easy maintenance.

Model	Description	
<a href="#"><u>8000-643-210</u></a>	<b>Standard Bypass Pump</b> 1.8 GPM open flow, Buna valves, Geolast® diaphragm, 35 PSI Bypass, 3/8" NPT-Female ports, Nylon Housing	<b>\$ 86.00</b>
<a href="#"><u>8000-543-250</u></a>	<b>Standard Bypass Pump</b> 1.8 GPM open flow, Viton® valves, Santoprene® diaphragm, 60 PSI Bypass, 3/8" NPT-Female ports, Poly Housing	<b>\$ 80.00</b>

## 8000 SERIES DIAPHRAGM PUMPS - BYPASS PUMPS 115VAC



Bypass Pump Demand Pump

### Features:

- Self priming up to 8 vertical feet (2.4m)
- Chemical resistant materials
- Designed for heavy duty spraying and fluid transfer applications
- Can run dry without damage

The 8000 Series diaphragm pump is SHURflo's most widely used industrial pump. With it's spherically shaped valves and internal bypass these pumps are the pump of choice for applications requiring consistent, dependable operation and priming. These 115 VAC pumps deliver up to 1.4 GPM (5.3 l/min). Pumps can be mounted in any position and are designed for easy maintenance.

Model	Description	
<a href="#"><u>8000-812-288</u></a>	<b>High Pressure Demand Pump w/Bypass</b> 1.4 GPM open flow, Viton® valves, Santoprene® diaphragm, 100 PSI Demand Switch w/80 PSI Internal Bypass, 3/8" FPT-Female ports, Nylon Housing	<b>\$125.00</b>

## 8007 SERIES DIAPHRAGM - AUTOMATIC DEMAND PUMP (12VDC W/ELECT. PACKAGE)

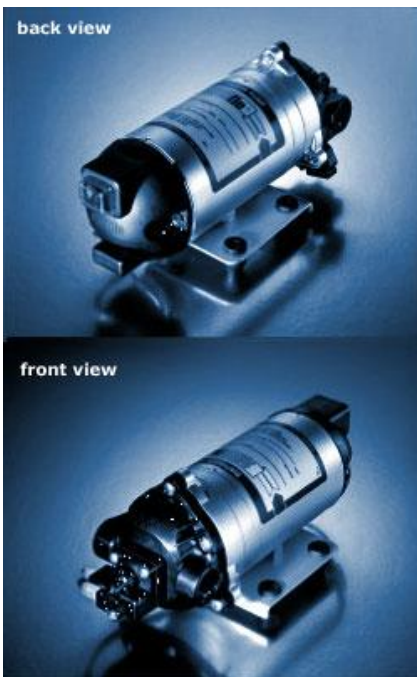

### Features:

- Self priming up to 8 vertical feet (2.4m)
- Chemical resistant materials
- Internal bypass
- Can run dry without damage

### Additional features of pump with Electrical Package:

- Built in on/off switch included
- 2 Pin connector on Power leads
- Available w/ or without integral fuse
- Rocker switch protected from the elements by a clear boot

These new models include an aesthetically pleasing molded assembly, housing a rocker-type manual switch with international on/off switch symbols. Wiring is neatly routed into the molded assembly through form fitting entries, and strain relieved inside the housing. Fused versions come with an automatic type fuse housed under a snug fitting cap marked "fuse" Non-fused versions have a raised section.

Model	Description	
<a href="#"><u>8007-543-836</u></a>	<b>Demand Pump w/ Electrical Package</b> 1.8 GPM open flow, Viton® valves, Santoprene® diaphragm, 60 PSI Demand with Elect. Pkg., 3/8" NPT-Female ports w/Manual On/Off Switch & 2 Pin Connector and Fuse, Poly Housing	<b>\$ 90.00</b>

## 8007 SERIES DIAPHRAGM BYPASS PUMP - 12VDC W/ELECTRICAL PACKAGE



### Features:

- Self priming up to 8 vertical feet (2.4m)
- Chemical resistant materials
- Internal bypass
- Can run dry without damage

### Additional features of pump with Electrical Package:

- Built in on/off switch included
- 2 Pin connector on Power leads
- Available w/ or without integral fuse
- Rocker switch protected from the elements by a clear boot

These new models include an aesthetically pleasing molded assembly, housing a rocker-type manual switch with international on/off switch symbols. Wiring is neatly routed into the molded assembly through form fitting entries, and strain relieved inside the housing. Fused versions come with an automatic type fuse housed under a snug fitting cap marked "fuse" Non-fused versions have a raised section.

Model	Description	
<a href="#"><u>8007-543-850</u></a>	<b>Bypass Pump w/ Electrical Package</b> 1.8 GPM open flow, Viton valves, Santoprene diaphragm, 45 PSI Bypass with Elect. Pkg., 3/8" NPT-Female ports. w/Manual Switch 2 Pin Connector and Fuse, Poly Housing	<b>\$85.00</b>

## 8020 SERIES DIAPHRAGM PUMPS – AUTOMATIC DEMAND PUMPS WITH POWER CORD 115 VAC



### Features:

- Self priming up to 8 vertical feet (2.4m)
- Chemical resistant materials
- Can run dry without damage
- Built-in check valve
- 6' power cord (1.8m)
- UL Listed
- CUL Listed

SHURflo 8020 Series demand pumps provide the same reliability as the 12 VDC version, with flow rates up to 1.7 GPM (6.4 l/min) except in 115 VAC They are ideal in industrial applications that require high pressure, with low amp draw. They can be mounted in any position, are compact, and are designed for easy maintenance.

Model	Description	
<a href="#"><u>8020-513-236</u></a>	<b>Standard Pump w/ 6' Power Cord</b> 1.5 GPM open flow, Viton® valves, Santoprene® diaphragm, 60 PSI Demand Switch, 3/8" NPT-Female ports, Poly Housing	<b>\$125.00</b>
<a href="#"><u>8020-833-238</u></a>	<b>High Pressure Pump w/ 6' Power Cord</b> 1.5 GPM open flow, Viton® valves, Santoprene® diaphragm, 100 PSI Demand Switch, 3/8"NPT-Female ports, Nylon Housing	<b>\$140.00</b>
<a href="#"><u>8030-863-239</u></a>	<b>High Pressure Demand Pump</b> 1.4 GPM open flow, Viton® valves, Santoprene® diaphragm, 150 PSI Demand Switch, 3/8"NPT-Female ports, Nylon Housing	<b>\$135.00</b>

## 8020 SERIES DIAPHRAGM PUMPS – BYPASS PUMPS WITH POWER CORD 115 VAC



Bypass Pump Demand Pump

### Features:

- Self priming up to 8 vertical feet (2.4m)
- 6' power cord
- Chemical resistant materials
- Can run dry without damage

SHURflo internal bypass pumps are the answer to applications where an automatic demand switch is not required. Pumps with bypass will continue to run at high pressure. Ideal for intermittent and continuous duty applications. They can be mounted in any position, are compact, and are designed for easy maintenance.

Model	Description	
<a href="#"><u>8020-503-250</u></a>	<b>Standard Bypass Pump w/ 6' Power Cord</b> 1.5 GPM open flow, Viton® valves, Santoprene® diaphragm, 45 PSI Internal Bypass, 3/8" NPT-Female ports, Poly Housing	<b>\$118.00</b>
<a href="#"><u>8020-822-299</u></a> (not shown)	<b>Externally Adjustable Bypass Pump w/ 6' Power Cord</b> 1.1 GPM open flow, Viton® valves, Santoprene® diaphragm. Externally adjustable Bypass, 3/8" NPT-Female ports, Nylon Housing	<b>\$145.00</b>
<a href="#"><u>8020-832-288</u></a>	<b>High Pressure Bypass Pump w/6' Power Cord</b> 1.4 GPM open flow, Viton® valves, Santoprene® diaphragm, 100 PSI Demand Switch, w/80 PSI Internal Bypass, 3/8" NPT-Female port, Nylon Housing	<b>\$138.00</b>

## 2088 SERIES DIAPHRAGM PUMPS – AUTOMATIC DEMAND PUMPS 12 VDC



Premium Pump w/ cooling fins Standard

### Features:

- Self Priming up to 12 vertical lift feet (3.7m)
- Built-in check valve (may vary by models)
- Prevents back flow of fluid through the pumps
- Continuous duty motor (fin cooled version only)
- Chemical resistant materials
- Can run dry without damage

SHURflo 2088 Series diaphragm pumps deliver reliable performance in high flow, moderate pressure applications. They are used in a variety of spraying, and transferring applications that require flows of up to 3.6 GPM (13.6 l/min). They are available in a variety of chemical resistant materials, can be mounted in any position, and are designed for easy maintenance.

Model	Description	
<a href="#"><u>2088-343-135</u></a>	<b>Standard Demand Pump</b> 3.0 GPM open flow, Viton® valves, Santoprene® diaphragm, 45 PSI Demand Switch, 1/2" MSPT* ports, Poly Housing	<b>\$ 98.00</b>
<a href="#"><u>2088-443-144</u></a>	<b>Standard Demand Pump</b> 3.5 GPM open flow, Santoprene® valves, Santoprene® diaphragm, 45 PSI Demand Switch, 1/2" MSPT* ports, Poly Housing	<b>\$105.00</b>
<a href="#"><u>2088-643-144</u></a>	<b>Standard Demand Pump</b> 3.2 GPM open flow, Buna valves, Santoprene® diaphragm, 45 PSI Demand Switch, 1/2" MSPT* ports, Poly Housing	<b>\$ 98.00</b>
<a href="#"><u>2088-313-145</u></a>	<b>Premium Pump w/Fin Cooled Motor</b> 3.6 GPM open flow, Viton® valves, Santoprene® diaphragm, 45 PSI Demand Switch, 1/2" MSPT* ports, Poly Housing	<b>\$201.00</b>
<a href="#"><u>2088-414-534</u></a>	<b>Premium Pump w/ Splash-Proof ShurCoted Motor</b> 3.6 GPM open flow, Santoprene® valves Santoprene® diaphragm, 45 PSI Demand Switch, 1/2" MSPT* ports, Poly Housing	<b>\$155.00</b>

## 2088 SERIES DIAPHRAGM PUMPS – BYPASS PUMPS 12 VDC



### Features:

- Self Priming up to 12 vertical feet (3.7m)
- Can run dry without damage
- Built-in check valve (may vary by models) prevents back flow of fluid through the pump
- Chemical resistant materials
- Continuous duty motor (fin cooled version only)

SHURflo 2088 Series diaphragm pumps deliver reliable performance in high flow, moderate pressure applications. They are used in a variety of spraying, and transferring applications that require flows of up to 4.0 GPM [15.1 l/min]. They are available in a variety of chemical resistant materials. They can be mounted in any position, and are designed for easy maintenance.

Model	Description		
<a href="#"><u>2088-514-500</u></a>	<b>Bypass No Control Pump</b> 4.0 GPM open flow, Santoprene® valves, Santoprene® diaphragm, 45 PSI Bypass, 1/2" MSPT* ports, Poly Housing	<b>\$132.00</b>	
<a href="#"><u>2088-343-500</u></a>	<b>No Control Pump</b> 1/4" Front Port No Switch, 3.3 GPM open flow, Viton® valves, Santoprene® diaphragm, 1/2" MSPT* ports, Poly Housing	<b>\$ 95.00</b>	
* 1/2" - 14 National American Straight Pipe Thread. Requires SHURflo swivel type fittings			

## 2088 SERIES DIAPHRAGM PUMPS – AUTOMATIC DEMAND PUMPS 24 VDC

### Features:



Premium Pump w/ cooling fins

Standard

- Self Priming up to 12 vertical feet (3.7m)
- Can run dry without damage
- Built-in check valve (may vary by model) prevents back flow through the pump
- Continuous duty motor (fin cooled version only)
- Chemical resistant materials
- Automatic Demand

SHURflo 2088 Series diaphragm provide the same reliability as the 12 VDC versions except in a 24 VDC capacity. They are ideal in industrial applications that require flow rates up to 3.6 GPM (14.0 l/min) with low amp draw. They are used in a variety of spraying, and transferring applications. They are available in a variety of chemical resistant materials. These 24 VDC pumps are ideal for off-road or road maintenance equipment applications.

Model	Description		
<a href="#"><u>2088-474-144</u></a>	<b>Standard Demand Pump</b> 3.0 GPM open flow, Santoprene® valves, Santoprene® diaphragm, 45 PSI Demand Switch, 1/2" MSPT* ports, Poly Housing	<b>\$92.00</b>	

## 2088 SERIES DIAPHRAGM PUMPS – AUTOMATIC DEMAND PUMPS 115 VAC



Premium Pump w/ cooling fins

Standard

Model	Description	
<a href="#"><u>2088-394-154</u></a>	<b>Standard Demand Pump</b> 3.2 GPM open flow, Viton® valves, Santoprene® diaphragm, 45 PSI Demand Switch, 1/2" MSPT* ports, Poly Housing	<b>\$135.00</b>
<a href="#"><u>2088-594-154</u></a>	<b>Standard Demand Pump</b> 3.3 GPM open flow, Santoprene® valves, Santoprene® diaphragm, 45 PSI Demand Switch, 1/2" MSPT* ports, Poly Housing	<b>\$113.00</b>
* 1/2" - 14 National American Straight Pipe Thread. Requires SHURflo swivel type fittings		

## 2088 SERIES DIAPHRAGM PUMPS – AUTOMATIC DEMAND PUMPS WITH POWER CORD 115 VAC

### Features:



- Self Priming up to 12 vertical feet (3.7m)
- Can run dry without damage
- Built-in check valve (may vary by model) prevents back flow of fluid into the solution tank
- Chemical resistant materials
- Automatic demand

SHURflo 2088 Series demand pumps provide the same reliability as the 12 VDC versions except in 115 VAC capacity. They are ideal in industrial applications that require flow rates up to 3.0 GPM [11.3 l/min] with low amp draw. They are available in a variety of chemical resistant material. They can be mounted in any position, and are designed for easy maintenance.

Model	Description	
<a href="#"><u>2088-394-144</u></a>	<b>Standard Pump with 6' Power Cord</b> 3.0 GPM open flow, Viton® valves, Santoprene® diaphragm, 40 PSI Demand Switch, 1/2" MSPT ports, Poly Housing	<b>\$146.00</b>
<a href="#"><u>2088-594-144</u></a>	<b>Standard Pump with 6' Power Cord</b> 3.0 GPM open flow, Santoprene® valves, Santoprene® diaphragm, 45 PSI Demand Switch, 1/2" MSPT ports, Poly Housing	<b>\$125.00</b>
* 1/2" - 14 National American Straight Pipe Thread. Requires SHURflo swivel type fittings		

## 2088 SERIES DIAPHRAGM PUMPS – AUTOMATIC DEMAND PUMPS 230 VAC



Premium Pump w/ cooling fins      Standard

Model	Description	
<b><u>2088-564-144</u></b>	<b>Standard Demand Pump</b> 3.0 GPM open flow, Santoprene® valves, Santoprene® diaphragm, 45 PSI Demand Switch, 1/2" MSPT ports, Poly Housing	<b>\$112.00</b>
* 1/2" - 14 National American Straight Pipe Thread. Requires SHURflo swivel type fittings		

## 2087 SERIES DIAPHRAGM AUTOMATIC DEMAND PUMP (12VDC WITH ELECTRICAL PACKAGE)



back view

### Features:

- Self Priming up to 12 vertical feet (3.7m)
- Chemical resistant materials
- Can run dry without damage
- Rocker switch protected from the elements by a clear boot



front view

### Additional features of pump with Electrical package

- Built-in on/off switch included
- 2 pin connector on power lead

These new models include an aesthetically pleasing molded assembly, housing a rocker-type switch with international on/off symbols. Wiring is neatly routed into the molded assembly through form fitted entries, and strain relieved inside the housing.

Model	Description	
<b><u>2087-593-135</u></b>	<b>Demand Pump W/Electrical Package</b> 3.0 GPM open flow, Viton® valves, Santoprene® diaphragm, 45 PSI Demand Switch, 1/2" MSPT ports, Poly Housing	<b>\$101.00</b>